

Jay Radio Remote Control

Xpair series

Overhead crane application



CONDUCTIX
wampfler



Safety guaranteed
Quick installation & maintenance
Easy to use

Xpair is a Jay radio remote control dedicated to standard overhead crane operation. It follows the Conductix-Wampfler tradition of bringing safety, functionality and ergonomics to industrial lifting operators. With 60 years' experience in the use of overhead travelling cranes, our technical teams have met the challenge of making Xpair a radio remote control that is safe, quick to install and easy to use!

Radio Remote Control Xpair

Take control, safely!



Table of contents

1. Benefits	P.4
2. Description	P.6
3. Kit	P.8
4. Accessories	P.10
5. Technical data	P.12

Benefits.1



Safety guaranteed

Operator safety is a fundamental value on which we work relentlessly.

PLC cat.2 pushbuttons release

Xpair provides safe release of buttons, PLC category 2. This innovation ensures that movements stop when buttons are released. Xpair thus meets the requirements of the **EN 15011** standard.

PLd cat.3 safety stop

Xpair also features a PLd category 3 safety stop button, as required by the European Machinery Directive 2006/42/EC.

Life signal in tandem operation PLC cat.2

Xpair ensures information transmission PLC cat.2 according to EN ISO 13849-1 and -2.

Timed installation

Nothing to wire, it's all ready!

Xpair's receiver is delivered pre-wired, making installation significantly easier and more time-efficient! The external antenna is also supplied preassembled.

Simplified mounting

Xpair receiver can be mounted on its support in two different but equally simple ways...

#1 Magnetic mounting: thanks to a set of magnetic studs, the Xpair receiver can be fixed without drilling! The magnets make it easy to position the receiver in the optimum spot for the radio link quality.

#2 Mounting by drilling the support: external mounting holes are provided on the receiver casing; a simple and solid solution, since it allows drilling holes without need to open the casing.

Choose the best radio channel with complete peace of mind!

3 possible operating modes:

- > **fixed channel with selection aid** to adapt to a frequency plan
- > **selection of a free channel at startup** to allow more radio systems to coexist
- > **channel agility:** the radio adapts to its environment by automatically changing channel in the event of disturbance



Radio Remote Control **Xpair**

Easy to use

Xpair is designed for practical, comfortable use. Operators appreciate its many ingenious details! Among them...

- > **6 double-speed pushbuttons** to control the 3 main crane movements!
- > **Excellent tactile feel of buttons** for precise control even when wearing gloves.
- > **1 removable battery**: time saving, operations continue while recharging! 40 hrs of optimized autonomy thanks to power regulation.
- > **2 attachment points for carrying straps**: to each his own! Neck, wrist, shoulder or torso straps.
- > **1 rubber edge protector** to shield the transmitters from shocks.
- > **1 protective silicone cover** to preserve tactile sensation when used in dirty environments (paint splashes, concrete, grease...)



Quick maintenance

Repair guaranteed

To conserve resources and save money, Xpair is repairable. All transmitter and receiver parts are replaceable and available for after-sales service.

Easy replacement of a lost or broken transmitter

Xpair offers a unique, highly intuitive pairing experience that guarantees a successful start-up of a new transmitter without climbing up onto the overhead crane. 3 brief steps, guided and secured by the receiver's audible and visual feedback, are all it takes to install a new transmitter, a key step in the start-up process.

Standardized battery recharging

A universal USB-C charger is used for the recharge of Xpair batteries.

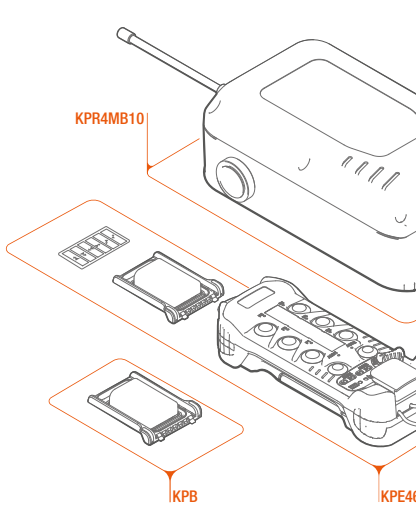

Simplified ordering

Xpair's simplicity of use starts right at the order stage!

You can't go wrong with Xpair: it's a single kit that can even be used in tandem! It can be configured on site according to customer requirements.

To complete the installation, a few additional references are available:

- > transmitter
- > multi-voltage receiver
- > accessories: silicone cover, magnetic studs, carrying straps, antennas, battery, charger

Description.2

Transmitter

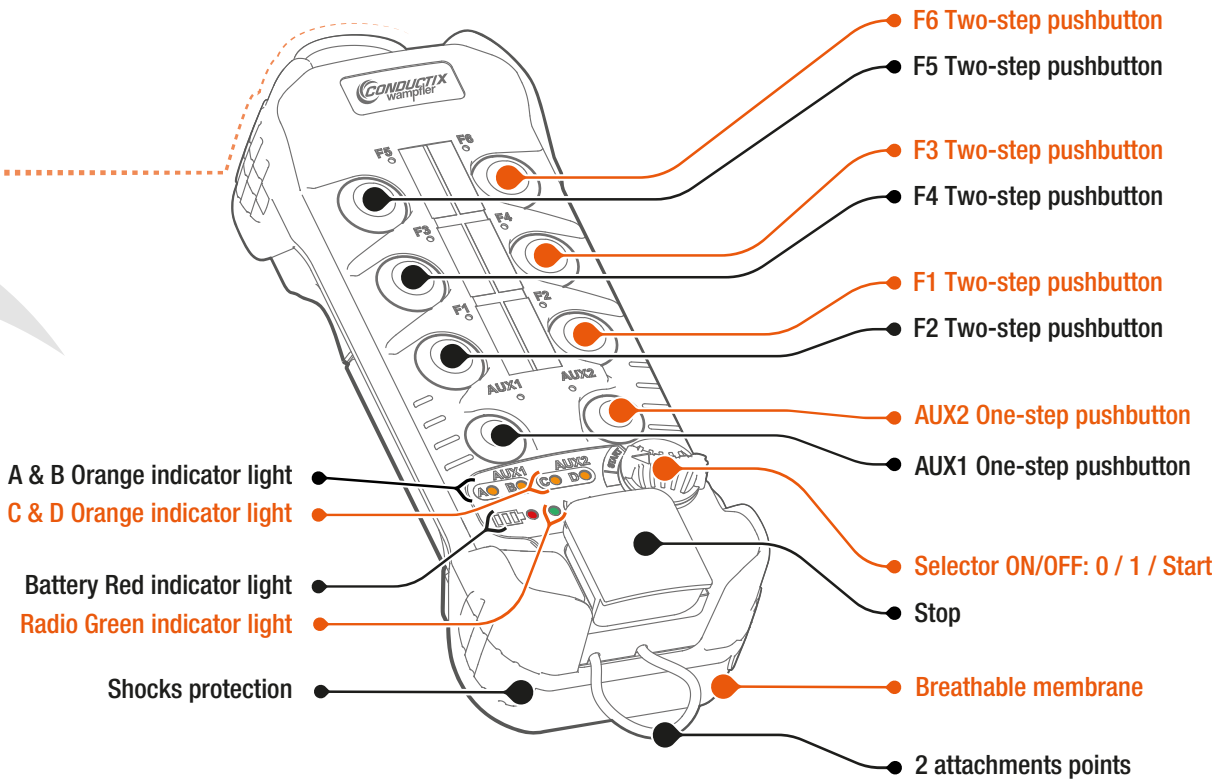

Safety



European Machinery Directive 2006/43/EC
EC-Type Examination Certificate issued by TÜV SÜD

> Safety stop Performance level PLd cat.3 according to EN ISO 13849-1 and -2

> 6x two-steps pushbuttons
Buttons release Performance level PLc cat.2 according to EN ISO 13849-1 and -2

> Life signal in tandem operation
Information transmission PLc cat.2 according to EN ISO 13849-1 and -2

Radio Remote Control **Xpair**

Receiver

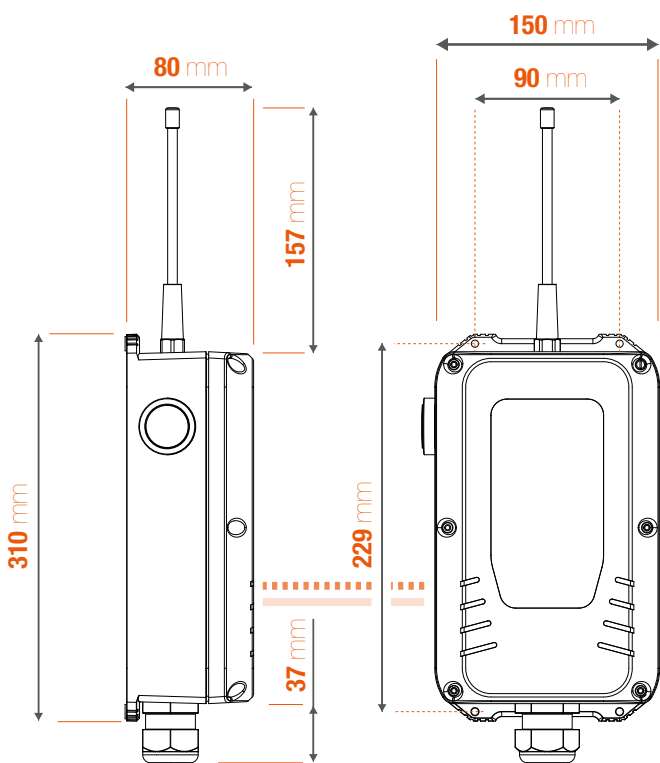
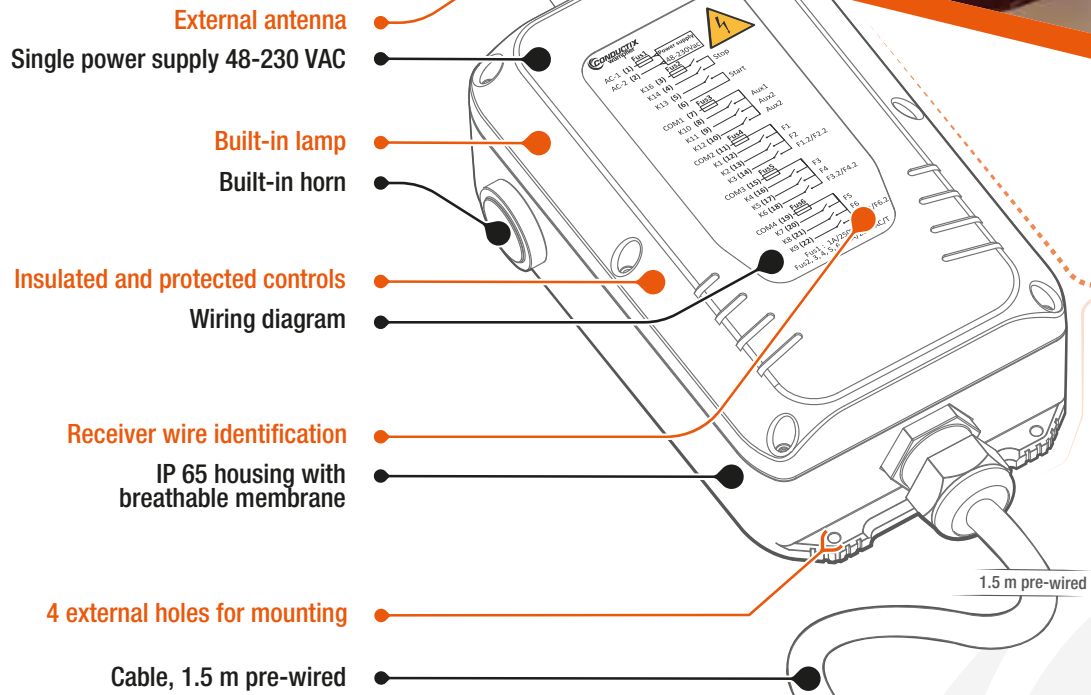

Kit.3

The Xpair kit is a single reference that includes all the elements needed for installation.

KPP46B01 Xpair kit

- 1x **KPE4650** (transmitter Xpair)
 - > 6 motion stickers (UWE202)
 - > 1x battery (KPB)
- 1x **KPR4MB10** (receiver Xpair)
- 1x **KPC** (charger + plugs + USB cable)
- 1x **KPB** (supplementary battery)
- 1x **UWE002** (adhesive directional arrows)

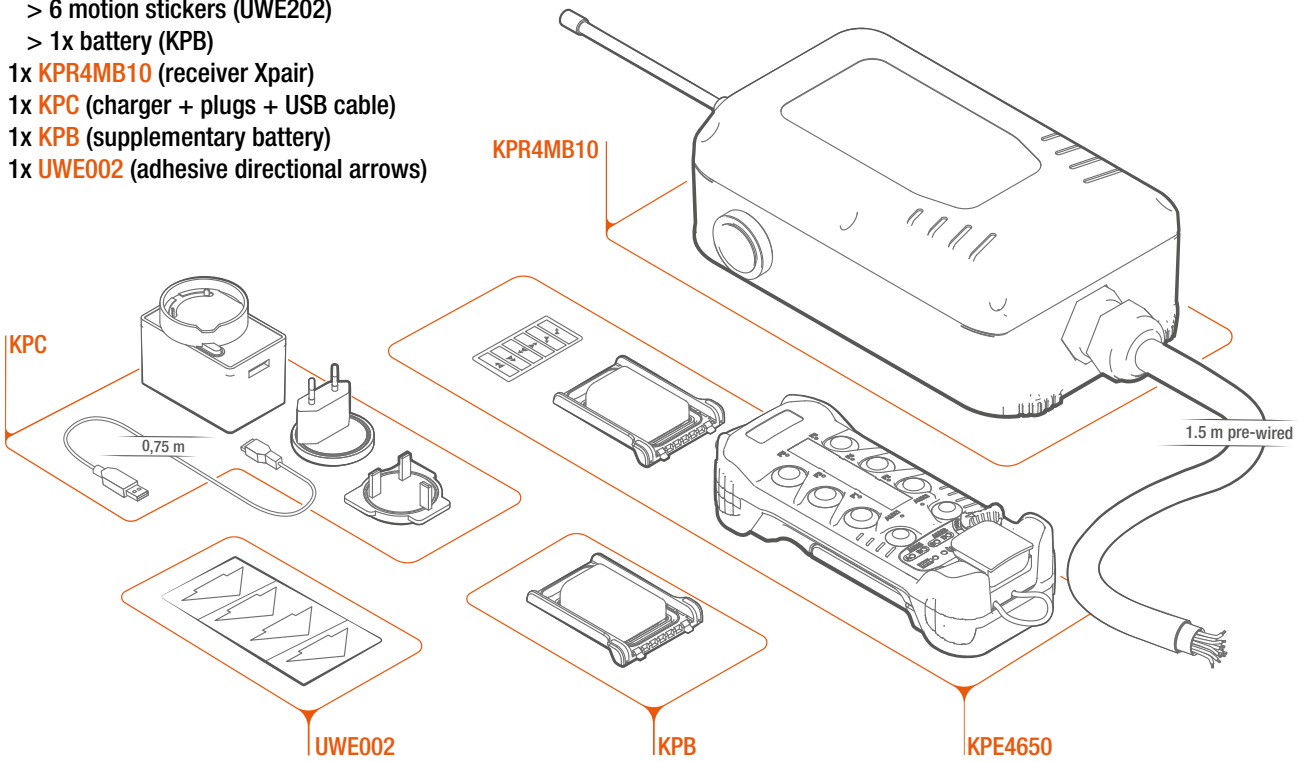

KPR4MB10 Xpair receiver

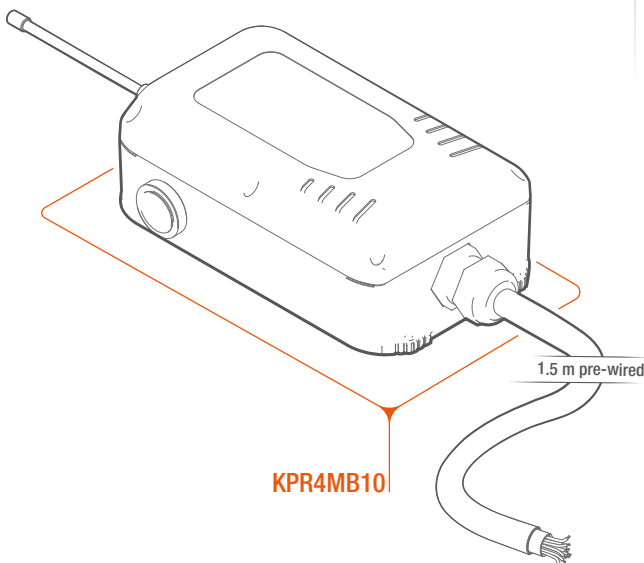

KPE4650 Xpair transmitter

- 1x **UWE202** 6 motion stickers
- 1x battery (KPB)

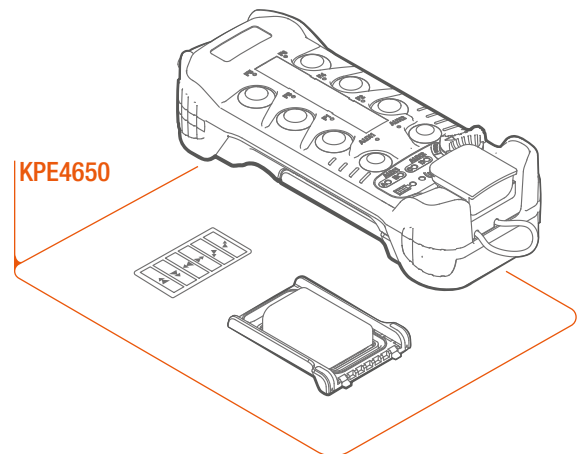

Radio Remote Control **Xpair**



1 kit, 1 reference: guaranteed efficiency! **Xpair**

Our commitment

In line with our environmental approach, a kit reference without charger KPP46B02 is available for future orders.

Accessories.4

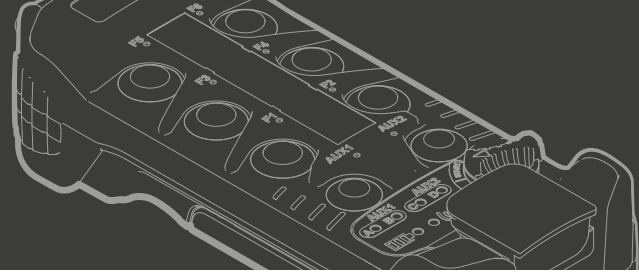

Transmitter accessories

OWE20 Removable 1-point lanyard



UWE102 Removable 2-points shoulder strap



UWE104 Removable 3-points shoulder strap



PWM111 Wrist strap



UWE106 Fixing belt



PWM107 Carrying sleeve



UWE320 2x silicon protective sleeves



PWM113 Magnetic fixing for transmitter



UWE202 6x transmitter motion stickers

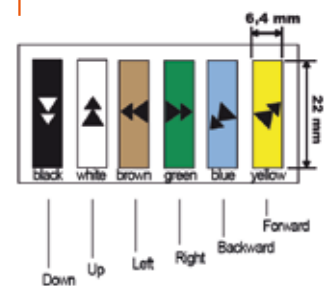

Radio Remote Control **Xpair**

Receiver accessories

UDWR38 Four-piece magnetic mounting kit

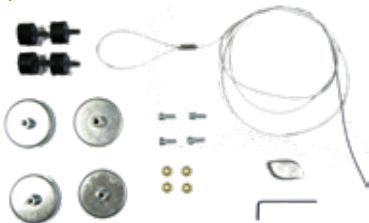

OWR02 MMCx - BNC adapter, 10 cm, to connect an additional antenna



UWE002 4x Self-adhesive directional colored arrows (122 x 180 mm) to stick on the overhead crane

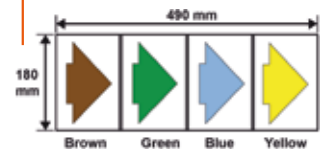

VUA103AM Insulated and magnetic remote antenna 419-434 MHz 1/2 wave, **3 m cable - BNC**

VUA105AM Insulated and magnetic remote antenna 419-434 MHz 1/2 wave, **5 m cable - BNC**

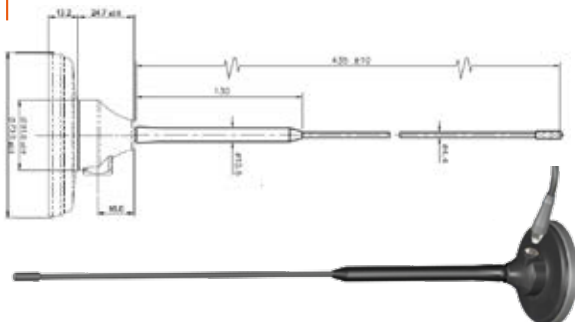

VUA100AH Through insulated remote antenna 419-434 MHz 1/2 wave **0.5 m cable - BNC**

VUA102AH Through insulated remote antenna 419-434 MHz 1/2 wave **2 m cable - BNC**

VUA105AH Through insulated remote antenna 419-434 MHz 1/2 wave **5 m cable - BNC**

VUA110AH Through insulated remote antenna 419-434 MHz 1/2 wave **10 m cable - BNC**

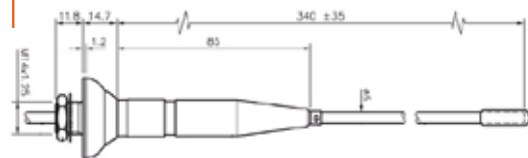

Various accessories

PWA-C USB A to USB C cable 0.75 m



KPB Supplementary plug-in battery 3.7 V 1600 mAh Li-ion



KPC 110-240 Vac adapter to charge KPB plug-in battery



Technical data.5

Radio

Transmission frequency	433.1 MHz to 434.7 MHz
Channel number	64
Modulation	Frequency Modulation
Frequency selection	Manual or automatic
Emission power	< 10 mW
Average range (1)	50 m - 100 m in industrial environment (1) / 400 m in open space (1)
Range limitation	Selectable 4 levels of power
Frame	Hamming 4 distance / Encryption against external attacks
Startup response time	500 ms
Response time of a command	300 ms

Transmitter

Housing	PA66 GF 30 / TPU / POM
Housing color	Yellow
Dimensions	180 x 70 x 45 mm
Ingress Protection	IP 65
Weight with battery	330 g
Command buttons	6 two-step pushbuttons. Buttons release PLc cat.2 according to EN ISO 13849-1 and -2. 2 one-step pushbuttons
Safety stop	2 positions with translation unlock system PLd cat.3 according to EN ISO13849-1 and -2
Power supply	Li-ion battery 3.7 V / 1600 mAh (KPB)
Autonomy	40 hours
Operating temperature	-20°C à +50°C
Storage temperature	-30°C à +70°C without battery
Attachment strap	2 points (2)
Prevention of condensation	Breathable membrane
Mechanical protection	Built-in protected foam and optional housing (2)
Indicator light	Radio link = green, Battery level = red, selection = 4x orange

Charge

Charging temperature range	0°C à +40°C
Full charging time	4 hours
Indicator	During charge, orange indicator light on battery / Battery full charge, green indicator light
Power supply	With KPC charger 110 - 240 VAC / 5 VDC

(1) Range varies according to environment conditions around transmitter and reception antenna (steel works, metal walls, etc.).

(2) Optional accessory RadioTransmitter

Pair

Pairing transmitters

- > 2 primary transmitters can be paired on each receiver (the regular transmitter and the reserve transmitter).
- > In Tandem mode, 2 secondary transmitters are possible (one regular and one reserve).
- > Transmitter/receiver pairing can be carried out without accessing the receiver, so there's no need to climb up onto the overhead crane.
- > Pairing a new transmitter automatically replaces the previous one.

Report

Signal the start of crane movement with the built-in horn

- > Each receiver honks its own pattern
- > Users who recognize the sound of their crane's horn know they've picked up the right transmitter to start the right equipment. No more mistaken transmitters and unintentional, dangerous starting of a neighboring crane.
- > Choice of 2 sound levels

Indicate

Make the receiver lamp flash to indicate, according to its pattern:

- > Free receiver
- > Receiver in use
- > Reserved receiver
- > Protected receiver
- > Pairing receiver

Receiver

House	PA66 GF 30 (cover PC 6710)
Housing color	Black case with translucent cover
Dimensions	310 x 150 x 80 mm / Without antenna / With cable gland and integrated horn
Mounting	4 x M3 screws - 229 x 90 mm (1)
Ingress Protection	IP65
Operating temperature	-20°C à +55°C
Storage temperature	-20°C à +70°C
Weight with cable	1400 g (with cable)
Power supply	Supply 48 Vac to 230 Vac $\pm 10\%$ / 50/60 Hz / Protected fuse 1A / Consumption < 15W Orange indicator light
Connection	22 strands multi-core cable / length approx. 1.5 m / Section 0.5 mm ² AWG 20 (0.5176 mm ² - 1,022 Kcmil)
Cable gland	M32 (cable Ø 13- 21 mm)
Stop function	2 relays Protected fuse 5 A / breaking capacity: > 250 Vac to 5A max (at max operating temperature) > 12 Vdc to 50 mA min 2000 VA for maximum power at $\cos \varphi = 1$ 100 000 switching cycles under 230 Vac, 6 A and $\cos \varphi = 1$ / Guided contacts AgNi + Au Red indicator light
Start and functions	13 relays (1x Start + 3x 3 motions + 3x auxiliaries) 3x protected fuses 5 A / breaking capacity: > 250 Vac to 5 A max (at max operating temperature) > 12 Vdc to 50 mA min 2000 VA for maximum power at $\cos \varphi = 1$ 100 000 switching cycles under 230 Vac, 6 A and $\cos \varphi = 1$ Contacts AgNi + Au Red indicator light for each relay
Radio link	Green indicator light
Horn	95 dB max with 2 power levels
Antenna	1/4 wave fixed antenna
Prevention of condensation	Breathable membrane

(1) Optional accessory

Settings⁺

Selecting the best radio channel

3 options for selecting the best radio channel:

Automatic selection at start-up / Automatic changeover during operation if another channel becomes more effective / Manual selection from 64 possible channels. A channel scan function is available to help select the best channel.

Find the best trade-off between radio range and battery life

Automatic adjustment of radio power to limit battery consumption. Possibility of limiting radio range by manual reduction of transmission power.

Secure use - A protection sequence secures:

- Access to the settings menu, to prevent unwanted modifications
- Start-up to limit access to the equipment.

Install the Tandem mode with different setting options

Selection of overhead cranes A and B. Automatic or voluntary release of an overhead crane during shutdown. Automatic shutdown of the second overhead crane in the event of loss of radio link with the first.

Manage standby mode

Standby so that the transmitter switches off or not after an inactivity timeout from 10 s to 99 min.

Radio Remote Control Xpair



Your applications - our solutions

The solutions we deliver for your applications are based on your specific requirements. In many cases, a combination of several different Conductix-Wampfler systems can prove advantageous. You can count on Conductix-Wampfler for hands-on engineering support together with the optimum solution to safely meet your needs.

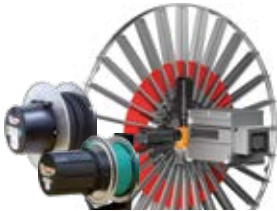

Cable and Hose Reels

Motor driven and spring driven reels by Conductix-Wampfler provide energy, data and media over a variety of distances, in all directions, fast and safe.



Festoon Systems

Conductix-Wampfler cable trolleys can be used in virtually every industrial application. They are reliable, robust and available in an enormous variety of dimensions and designs.



Conductor Rails

Available as enclosed, multiple or unipole systems, Conductix-Wampfler conductor rails reliably move people and material.



Inductive Power Transfer

The no-contact system for transferring energy and data. For all tasks that depend on high speeds and absolute resistance to wear. Flexible installation when used with Automated Guided Vehicles.



Non-insulated Conductor Rails

Robust, non-insulated aluminum conductor rails with stainless steel cap provide the ideal basis for power supply of people movers and transit networks.



Radio Remote Controls

Safety remote control solutions customized to meet our customer needs with modern ergonomic design.



Reels, Retractors and Balancers

Available for hoses and cables, as classical reels or high-precision positioning aids for tools, we offer a complete range of reels and spring balancers.



Jib Booms

Complete with tool transporters, reels or an entire media supply system – safety and flexibility are key to the completion of difficult tasks.

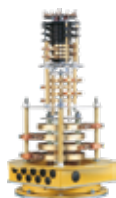

Slip Ring Assemblies

Whenever things are really "moving in circles", the proven slip ring assemblies by Conductix-Wampfler ensure the flawless transfer of energy and data. Here, everything revolves around flexibility and reliability!



Mobile Control Systems

Mobile control solutions for your plant – whether straightforward or intricate. Control and communication systems from LJU have been tried and tested in the automotive industry for decades.



ProfiDAT@

This data transfer system is a compact slotted waveguide and furthermore can be used as Grounding rail (PE) as well as positioning rail at the same time.



Charging Solutions

Whether inductive or conductive, this bundle of products offers always the perfect solution for all industrial charging tasks including matching the battery with the integrated BMS.

www.conductix.com

Conductix-Wampfler

has just one critical mission:
to provide you with energy and
data transmission systems that
will keep your operations up
and running 24/7/365.

To contact your nearest sales
office, please refer to:
[www.conductix.com/contact-
search](http://www.conductix.com/contact-search)

